

# **COMPUTER GENERATED HOLOGRAPHY**

Sponsored Professor: William Ames

Canh Ngoc Cao

## I. INTRODUCTION

Three-dimensional (3D) displays have been used and applied widely in computer graphics. Recently, holography has become the most popular method for rendering high quality three-dimensional graphics. The general term “Hologram” is used to define a three-dimensional picture produced from laser-light beams being scattered off of an object and interfered with a reference beam. A two-dimensional recording medium, a photosensitive plate or holographic film, will record three-dimensional information of an object which is called fringe pattern. This procedure is similar to photography where white light scattered from photographed objects is recorded on silver halide film. Light has a phase and amplitude (intensity) but only the latter is recorded in normal photography. However, a hologram can also store the phase of light due to the interference of the reference beam. This reference beam has the same characteristics as scattered light because of the action of the laser unlike the white light where things are random. The phase information is the most important factor in holography because it provides the depth cues to the eyes and allows for an image to appear in three-dimensions. In computer science field, a computer generated holographic image is computed by numerically simulating the physical phenomena of light diffraction and interference. It is possible for a computer software to calculate the phase of light of an object. In my thesis, I implemented a computer program that is able to generate holograms by computing the phase of light of different objects such as points, lines and wire frames.

## **II. INVESTIGATE APPROACH**

A common approach is a ray-tracing method in which the contribution from each object point source is computed at each point in the hologram plane. This method requires one calculation per image point per hologram sample, so it is very slow. One of my goals in this project is to optimize the algorithm for the improvement of speed. I have discussed with Professor William Ames about my thesis, and we decide to focus on the computation of off-axis transmission holograms.

## **III. INVESTIGATE EQUIPMENTS ON CAMPUS**

The hologram must be produced at very high resolution because it is not a recording of a focused image as in photography, but the recording of the interference of laser light waves that are bouncing off the object with another coherent laser beam. This is also true for the computer generated holographic images. A computer-generated hologram will be stored in a tiff format file. This tiff file then will be printed on film at high resolution. The two places on campus that can provide us with such equipment are the Interactive Multi-media Lab (IML) and Audio Video (AV). We created a series of test images, that are uncompressed tiff files, containing many distinguishable lines within certain width. We then printed these images on film using one of the available equipment on campus to check the resolution's capability.

Also, we need to assemble some equipment (laser, lenses, etc) for displaying the holograms that we produced. The equipment can be bought or the physics department can let us have access to their laboratory.

#### **IV. GENERATE HOLOGRAM**

Finally, my main goal for this thesis is to generate the actual holograms on computer. I will implement the computation of off-axis method and the ray-tracing approach. The program, that I implemented, is capable of generating holograms of points, lines and polygons. The speed of my program must be taken into consideration. With help from my sponsored professor, William Ames, the program is optimized for improved speed. My thesis focuses on the computation of off-axis transmission holograms possessing both horizontal and vertical parallax.

##### **1. Point Hologram**

A standard photograph is only the recording of the different intensities of the light reflected by the object and imaged by a lens. Because the light source is incoherent there are different wavelengths of light reflecting from the object and even the light of the same wavelength is sometimes out of phase. However, the laser emits a single wavelength coherent light. In order to record the three-dimensional information of the object, we need a reference source and object beams in order to record the phase difference of the light waves and therefore capture the information that supplies the crucial dimensions and depth cues. The following figure depicts the idea:

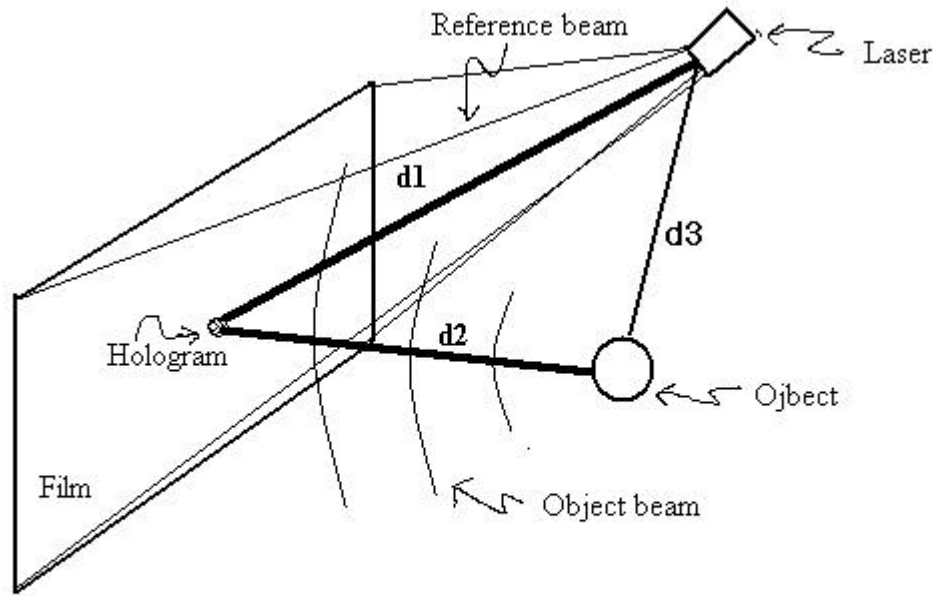

General geometry for point hologram

Figure 1

From the general geometry for making the point hologram, we can derive a mathematical formula to calculate the phase of light.

Let  $\lambda$  be the wavelength of the laser beam, and  $k$  is a constant.

Let  $d_1$  be the distance from the reference beam to the film (image plane).

Let  $d_2$  be the distance from the real object to the film.

Let  $d_3$  be the distance from the reference source to the object.

We then can formulate an equation:

$$\text{Phase of light} = \frac{2\pi}{\lambda} (d_2 + d_3 - d_1)$$

The distance from object **d1**, and reference beam **d2** and the distance from the reference source to the object **d3** can be computed with a simple C function. We can represent the position of the reference beam and the position of the object in three-dimensional coordinate (X,Y,Z). The coordinates of the image plane are also known therefore the calculation of **d1**, **d2**, and **d3** can be done with the following formula:

$$D = \sqrt{x^2 + y^2 + z^2}$$

Since the magnitude of the wavelength is also known, I wrote a C++ function that computes the phase:

```
float point::phase(point3d imagepixel, point3d Refbeam, float WaveLength)
{
// Point is the coordinate of the object

// calculate distance from the object to the image plane
float dx=Point.x-imagepixel.x;
float dy=Point.y-imagepixel.y;
float dz=Point.z-imagepixel.z;
float distance = sqrtf(dx*dx + dy*dy + dz*dz);

// calculate distance from the object to the reference source
float drx = Point.x - Refbeam.x;
float dry = Point.y - Refbeam.y;
float drz = Point.z - Refbeam.z;
float distance2 = sqrtf(drx*drx + dry*dry + drz*drz);

// calculate the distance from the reference source to the image plane
float dbx = imagepixel.x - Refbeam.x
float dby = imagepixel.y - Refbeam.y
float dbz = imagepixel.z - Refbeam.z
float refdist = sqrtf(dbx*dbx + dby*dby + dbz*dbz);

// calculate and return the phase of light at pixel X,Y on the image plane
return cosf((distance + distance2 - refdist)/WaveLength);
}
```

The phase function will be called at each pixel of the image plane. The following point-hologram is produced by the above function:

Notes: The below picture is cropped from the actual hologram because the actual dimension of the point hologram is 4096x2730 which is quite large.

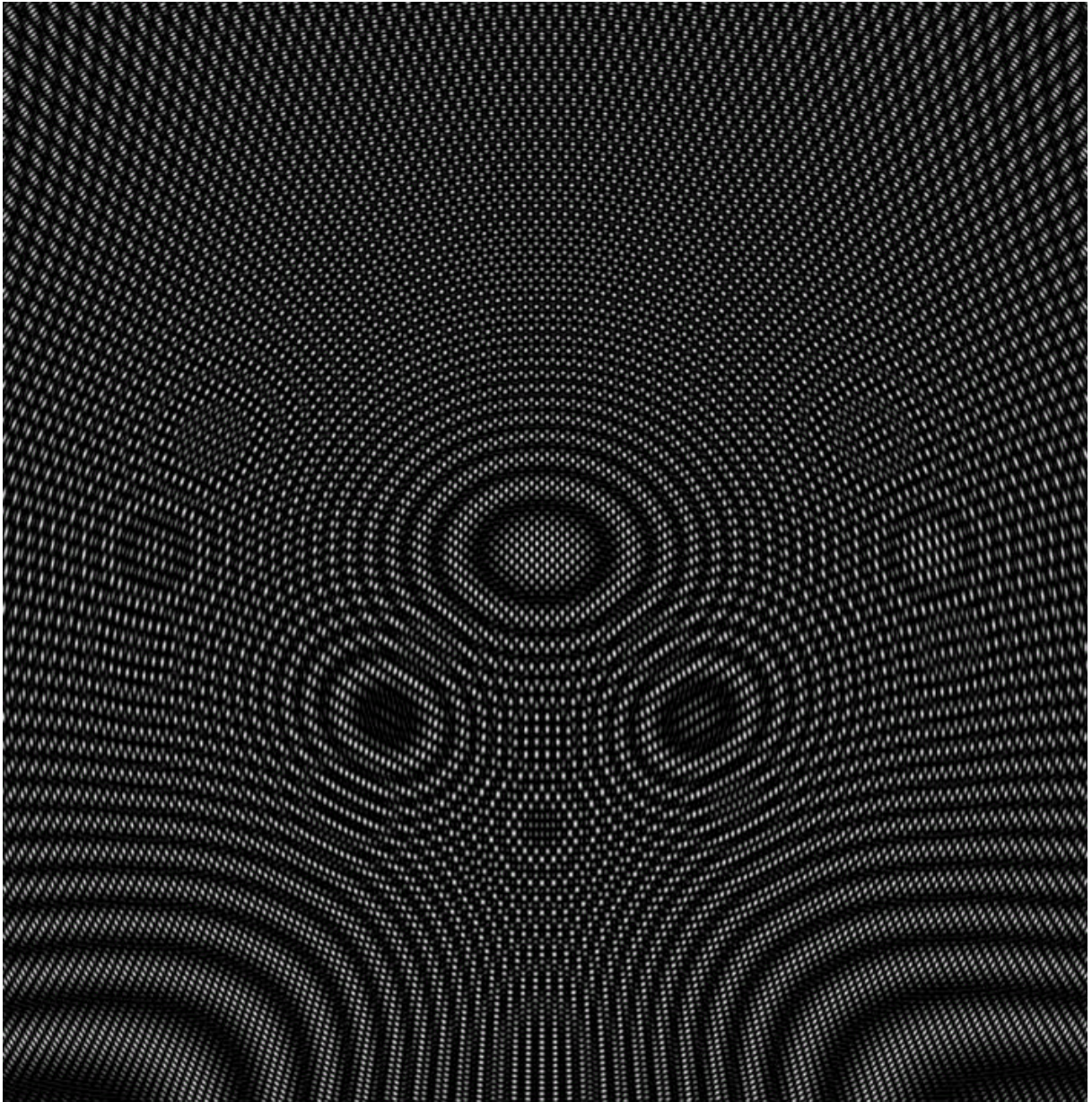

A point hologram



## 2. Line Hologram

The general geometry for line hologram is similar to the geometry of point hologram:

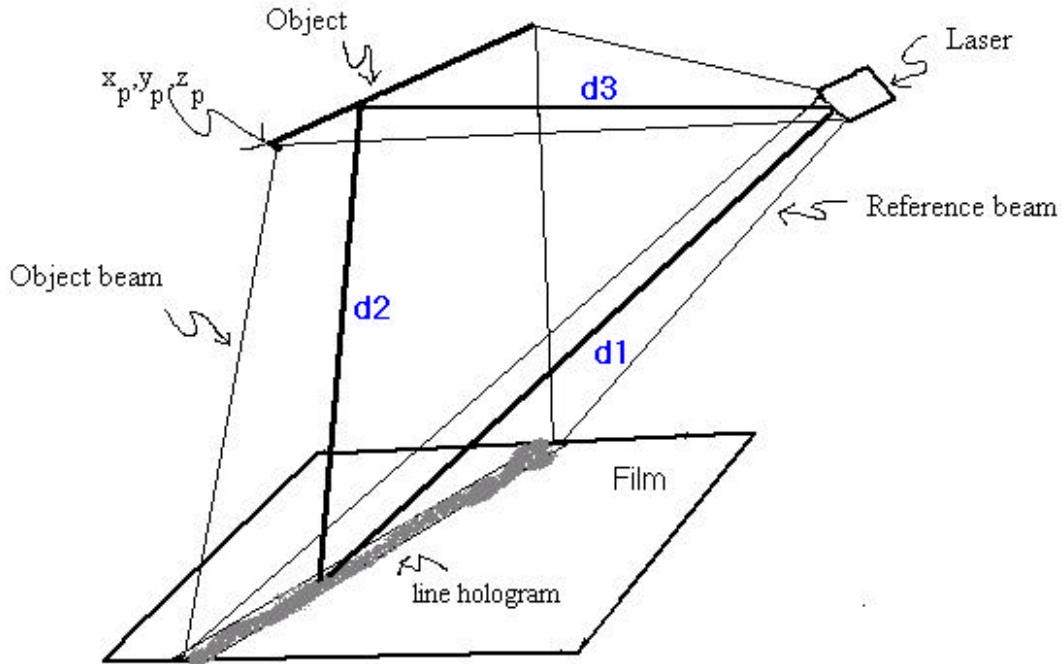

Geometry for line hologram

Figure 2

We now can examine the numerical computation of a line holographic pattern, beginning with the simple physics of point-source light propagation. We consider the position of the hologram at the  $z = 0$  plane, and the hologram plane contains horizontal  $x$ -axis and vertical  $y$ -axis. Every point of the object, i.e. the line, emits light from position  $(x_p, y_p, z_p)$ . A line is represented only by two end points. We need to find all the points that are between the two given end points. Each point on the actual line is computed with following formulas:

$$X = x_1 + t * (x_2 - x_1)$$

$$Y = y_1 + t * (y_2 - y_1)$$

$$Z = z_1 + t * (z_2 - z_1)$$



Where  $t = 1/\text{Numpoints}$ , and Numpoints is the number of points between the two given end points that virtually form a line.

The distance from the points on the object to the hologram **d2**, and the distance of the reference beam **d1** and the distance from the object to the reference source **d3** can be computed similar to the point hologram. The computational algorithm of the phase for the line hologram differs from the point hologram's. At each pixel on the hologram, we also need to compute all the points (X,Y,Z) that make up the actual line. Since the wavelength is a constant, we can form an equation that represents the phase of light:

$$\text{Phase of light} = \text{Cos}((\mathbf{d2} + \mathbf{d3} - \mathbf{d1})/\text{Wavelength})$$

I wrote a C++ function for the above equation:

```
float line::phase(int numpoints, point3d imagepixel, point3d Refbeam, float WaveLength)
{
    float t, sum=0.0f;
    float dx, dy, dz, distance, distance2;
    point3d p;

    // distance from the reference source to the image plane
    float drx = imagepixel.x - Refbeam.x;
    float dry = imagepixel.y - Refbeam.y;
    float drz = imagepixel.z - Refbeam.z;
    float refdist = sqrtf(drx*drx + dry*dry + drz*drz);

    float tincrement = 1.0/numpoints;
    float pdx = point2.x - point1.x;
    float pdy = point2.y - point1.y;
    float pdz = point2.z - point1.z;
```

```

// This loop will calculate all the points that made up the line
// the number of points must be given, we choose 100 points
for (t = 0.0f; t <= 1.0f; t+=tincrement) {

    // compute the all the points that made up the line
    float x = point1.x + t*(pdx);
    float y = point1.y + t*(pdy);
    float z = point1.z + t*(pdz);

    // the distance from the line to the image plane
    dx=x-imagepixel.x;
    dy=y-imagepixel.y;
    dz=z-imagepixel.z;
    distance = sqrtf(dx*dx + dy*dy + dz*dz);

    // distance from the line to the reference source
    dx=x-Refbeam.x;
    dy=y-Refbeam.y;
    dz=z-Refbeam.z;
    float distance2 = sqrtf(dx*dx + dy*dy + dz*dz);

    // the phase of light of the line is the average sum of all the phases of points

    sum += cosf((distance+distance2-refdist)/WaveLength);
}

return sum;
}

```

Here is the line hologram produced by the above phase function:

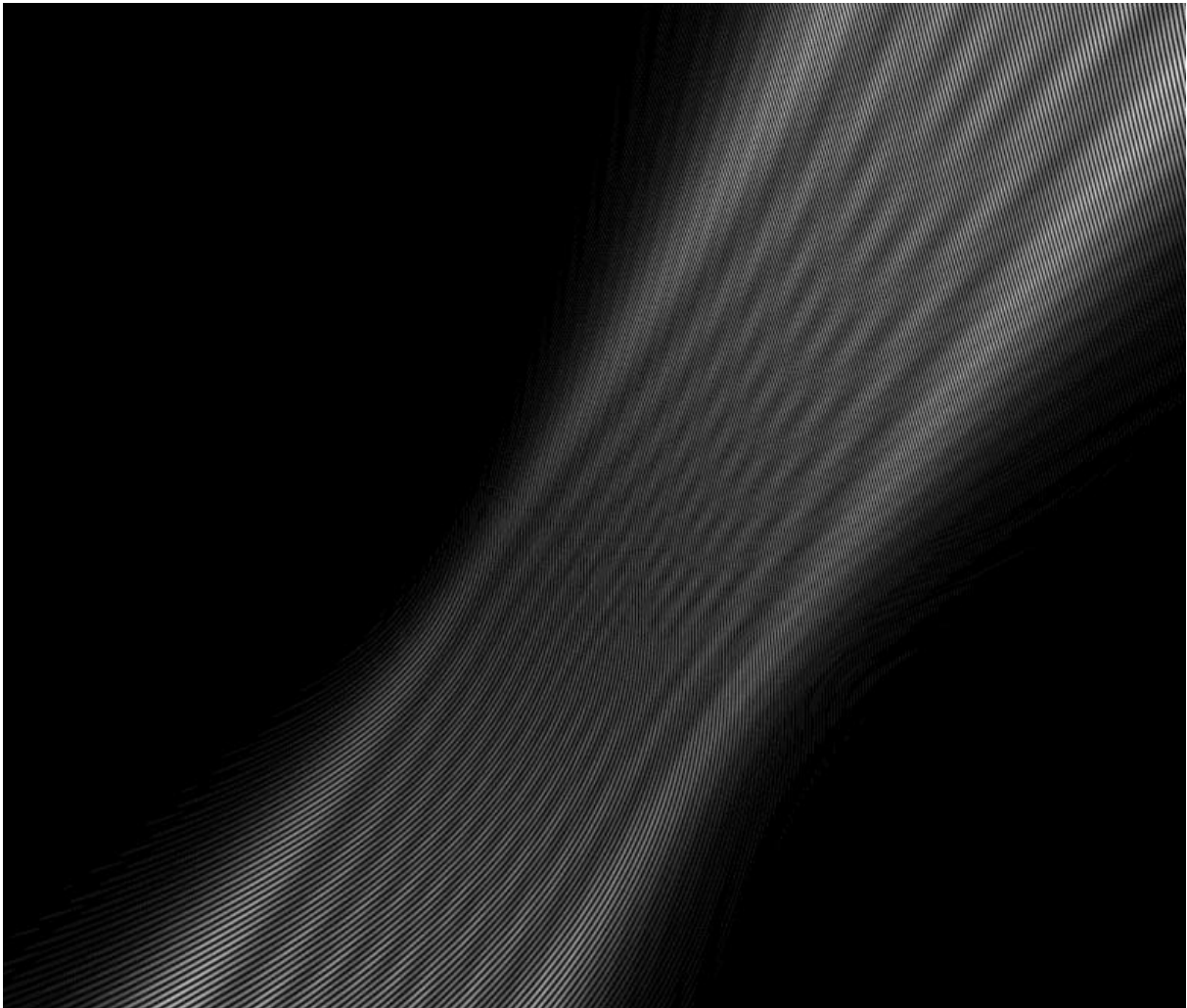

The image is also cropped from the actual image due to its high resolution.

### **3. Viewing the Computer Generated Hologram:**

We used a laser which shined through a beam expander/collimator (a photographed camera's lens) into the Computer Generated hologram. This method is the simplest way to view a Computer Generated hologram by looking through the Computer Generated hologram at a point source.

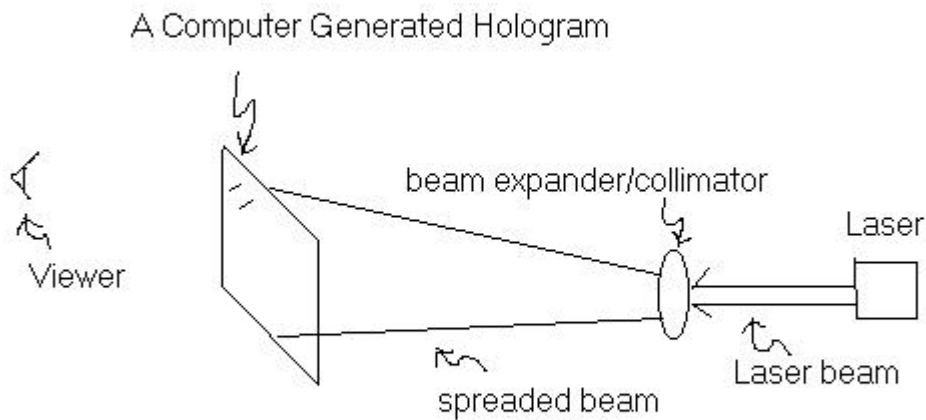

**Figure 3: Viewing Computer Generated Hologram**

#### **4. Holograms are stored in TIFF format**

At the beginning of the thesis, I produced a Computer Generated Hologram by emitting the hologram's pixels into a PGM (Portable Graymap) file format. Since I wrote my program on the Computer Science machine of Boston College, I was able to examine the outcome of the hologram with XV. However, the process used to produce the results, that can be viewed in three-dimensions, was to photograph the masks using a 35mm camera and slide film. The slides are illuminated with a laser to produce the projected hologram. The equipment, that can accomplish such task at Boston College's Interactive Media Lab, requires the file format to be in uncompressed TIFF file format. I discussed with Professor Ames, and we decided to write our own TIFF library based on the TIFF 6.0 Specification. The TIFF

library, that we wrote, will store uncompressed images. Due to nature of our TIFF library, the size of the Computer Generated Hologram is quite large. A line hologram with resolution of 4096x2730 occupies about 10 Megabytes of hard drive spaces.

## 5. Optimization

The running time of each Computer Generated Hologram is different depending on the resolution of the image. In fact, the running time is proportional to the image width and height. For example: the running time for a hologram of 4096x2730 will be proportional to the product of 4096 times 2730. We observed the running time of both the point hologram and line hologram programs, and we noticed that the line hologram program had the most running time. We examined the codes and found out that since the phase function of the line hologram iterates N times, where N is number of given points between two given end points. Besides there are two square-root functions and a cosine function called in each iteration. To improve speed, I edited the codes and changed the square-root function to a modified iterative approximating square-root algorithm. These square-root functions are used to compute the distances whose values change slightly in each iteration. Suppose distance D is computed using the following formula:

$$D = \sqrt{x^2 + y^2 + z^2}$$

The above function is needed to calculate the value of D at the very beginning of the phase function. When the phase function loops through the number of given points, we can approximate the square-root function as follow: we add the current value of D with the quotient of  $(x^2 + y^2 + z^2)$  and D. The sum then is divided by 2, the result will be the approximated square-root value:

$$D = \frac{D + \left( \frac{x^2 + y^2 + z^2}{D} \right)}{2}$$

Using this algorithm, we are able to reduce the running time of the line hologram program to 30%. The following line hologram is produced with our new square-root algorithm:

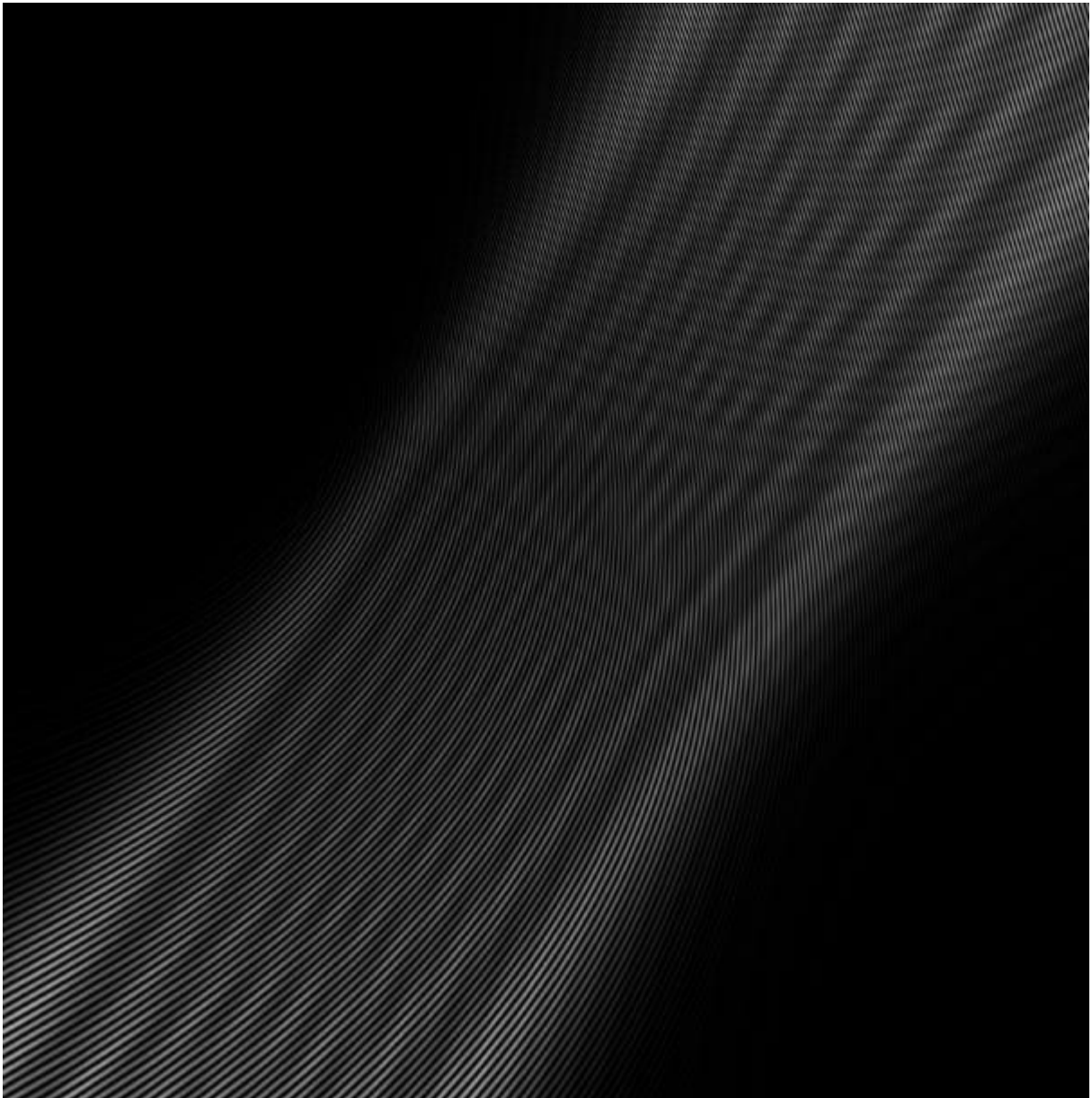

We also investigated in writing our own cosine function that uses the technique for iterative approximation. We got the negative result because Professor Howard Straubing pointed out that eventually the approximating cosine values would diverge throughout the loop. After failing the first attempt to modify the cosine function, I tried to apply the Mclaurin series to compute the cosine function. The formula is:

$$\text{Cos}(x) = 1 - \frac{x^2}{2!} + \frac{x^4}{4!} - \frac{x^6}{6!} + \frac{x^8}{8!} - \frac{x^{10}}{10!} + \dots$$

This method also failed to improve the speed of the program if I used more than 10 polynomial terms. When I used fewer polynomial terms the approximating cosine value is not accurate enough.

#### **IV. CONCLUSTION**

Computer Generated Holograms are still at the beginning stage, and so much more can be done. My thesis can be improved in future if I can create a Computer Generated Hologram using an OpenGL library. The advantage of OpenGL is that it is possible to read the Z-buffer of an image. Using the Z-buffer values, it is also possible to compute the dimensions and depth cues of the image, thus more realistic holograms can be produced.

The applications of Computer Generated Holograms are many. Once the technology for producing interactive holograms can be done in real time, we can watch television in three-dimensional view. Teachers can enhance their lectures by showing an interactive hologram of any object and model. For this reason I felt that Computer Generated Hologram can be viewed as an effective teaching tool.



## **V. ACKNOWLEDGEMENT**

My thesis has involved much time spent on researching the topic of Computer Generated Hologram and implementing computer program. I greatly appreciate the time and effort that my sponsored professor, William Ames, spent to make the final result possible. I have learned a great deal from my thesis. I also would like to thank Professor Howard Straubing for pointing out the problem of the approximating cosine function. Finally, I thank Boston College Interactive Media Lab and the Audio Video department for their contribution to the process of printing the Computer Generated Hologram on film and slide.

**Bibliography:**

1. TIFF 6.0 Specification Coverage by Sam Leffler / sam@engr.sgi.com
2. Optimization of Hologram Computation for Real-Time Display  
By Mark Lucente, MIT Media Laboratory published in SPIE, Bellingham, WA, Feb. 1992
3. Optical Information Processing and Holography  
By W. Thomas Cathey, University of Colorado, Denver, Colorado
4. CRC Standard Mathematical Tables 25<sup>th</sup> Edition  
By William H. Beyer, Ph.D